

NOTE:

1. SUPPORT PIPING SO THAT THERE IS NO WEIGHT ON PUMP.
2. PROVIDE INERTIA BASE WHEN REQUIRED BY SPECIFICATION, OTHER DETAILS OR SCHEDULES.

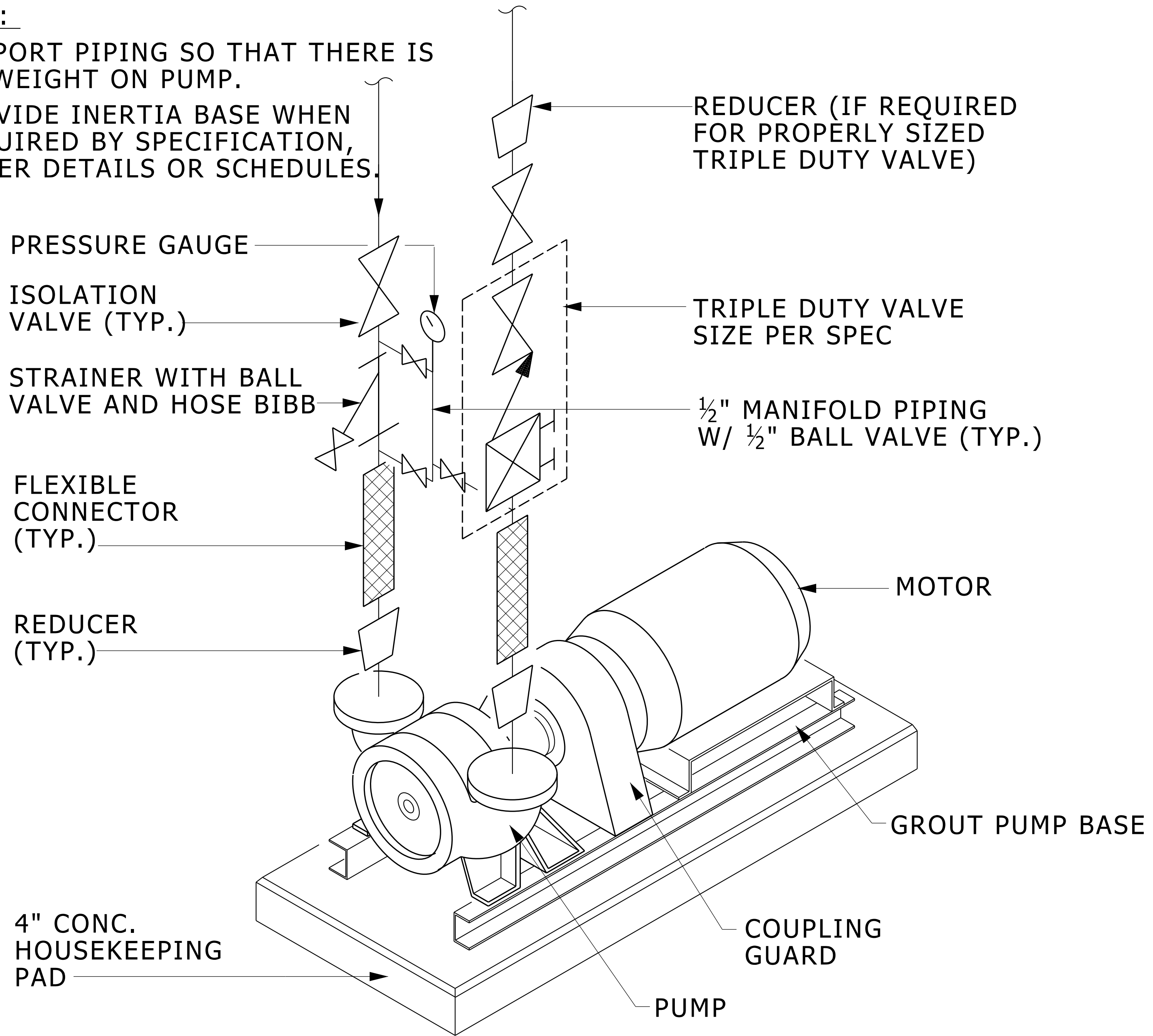

VERTICAL SPLIT CASE PUMP INSTALLATION DETAIL

NO SCALE

D 15160 003 11 12.dgn

DESIGNER NOTE: FOR VARIABLE VOLUME SYSTEMS,
DELETE TRIPLE DUTY VALVE AND SHOW A CHECK
VALVE INSTEAD.

REFERENCED DETAILS/SCHEDULES:
S 15160 001 S 15130 001 D 15160 002

ADDITIONAL INFORMATION:

MODULES: 1

M UNIVERSITY OF MICHIGAN
ARCHITECTURE, ENGINEERING AND CONSTRUCTION

ARCHITECTURE & ENGINEERING
326 East Hoover, Mail Stop B
Ann Arbor, MI 48109-1002
Phone: 734-764-3414
Fax: 734-936-3334

Vertical Split Case Pump Installation Detail

DIVISION: 15
SECTION: 15160
FILE: D 15160 003 01 12.dgn
ISSUE DATE: 11/01/12